

SOLAR DOMESTIC HOT WATER APPLIANCE

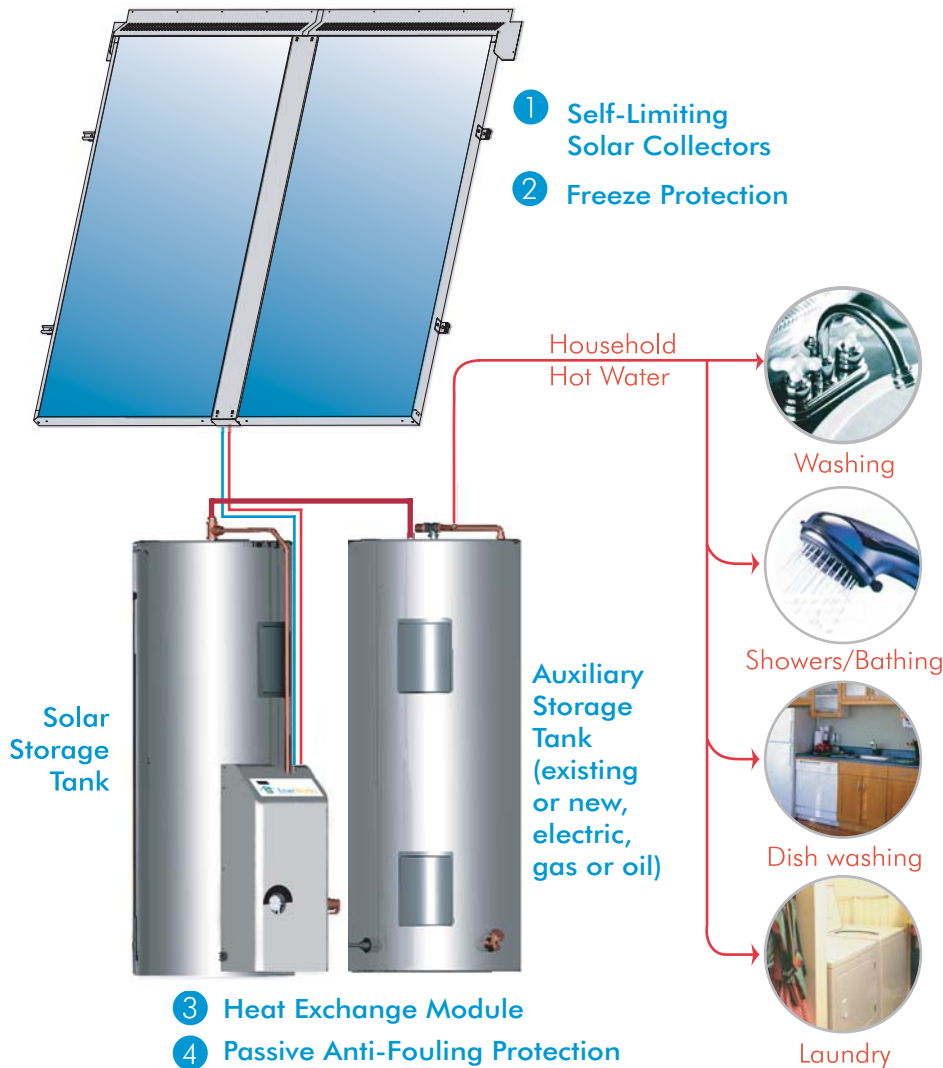

Product Features

- 1 The Self Limiting Solar Panels,*** or Solar Collectors, are designed with a self-regulating mechanism to allow hot air to vent, preventing overheating on a hot summer day. The system is also freeze protected. The solar collectors can be roof, fence or rack mounted. * Patent Pending
- 2 Freeze Protection,** the use of food grade glycol solution supports system operation even in extremely low ambient temperatures (-40 C).
- 3 The Heat Exchange Module** transfers free solar energy to heat the water. Hot water is available throughout the day to meet household needs. Solar heated water is produced during sunny periods; electricity, gas or oil heats the water during cloudy periods.
- 4 EnerWorks patented Passive Anti-Fouling Protection** ensures that the heat exchanger module functions at optimal levels preventing clogging of the module, a common problem with many solar water heaters.

Preheat Model

The Preheat Solar Domestic Hot Water Appliance from EnerWorks is the first in a series of renewable energy appliances suitable for new or replacement residential applications. The EnerWorks Hot Water Appliances act as the primary source of your family's hot water, while your existing electric, gas or oil hot water heater functions as an auxiliary storage system.

EnerWorks appliances are the world's first in-home renewable energy products that supply energy for less than the cost of grid electricity. Solar energy at 6¢ CAD/4¢ US per kWh represents Real Savings. Choosing emission-free Green Energy is a logical step to a clean environment and savings in your pocket.

How it Works

Solar energy is captured by **1** the solar panels. A heat exchange module **3** transfers the energy to heat the water. The panels can be roof, fence or racks mounted, almost anywhere with a southern exposure.

Solar Calculator: www.enerworks.com/flash/solar_calculator.swf

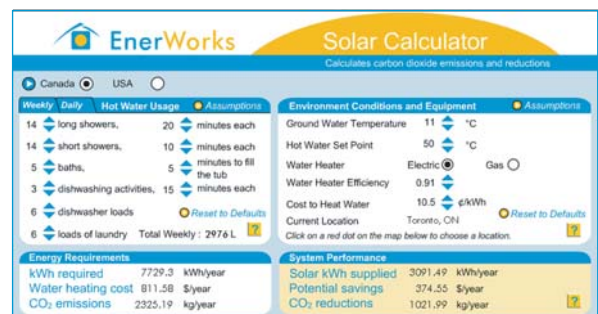

Product Performance

Product performance varies with household hot water use patterns and geographic location. To review product performance for a specific location, please visit: www.enerworks.com/flash/solar_calculator.swf

Performance independently verified by Bodicote Material Testing at the National Solar Test Facility in Toronto, Canada.

EnerWorks Product Specifications

Solar Panels	One, two or three, 4' x 8' (3m ²) collector(s), 110 lb (50 kg), proprietary design. Patent pending.
Absorber	Copper tube on Aluminum sheet absorptance >90%, emittance <10%
Glazing	Low iron tempered glass
Housing	3" (7.6 cm) deep - Stainless Steel
Heat Exchange Module	30 lb. (13.6kg)
Pump	120 VAC, nominal 15 Watts
Controller	Differential temperature controller CSA/UL approved.
Heat Transfer Fluid	Food Grade Propylene Glycol and distilled water mix. The system operates at 15 psi. nominal, 40 psi maximum.
Expansion Tank	Coated Steel Tank w/ internal Bladder
Heat Exchanger	Brazed-plate, stainless steel 316 Integral patented passive Anti-Fouling Protection

EnerWorks Accessories

Mounting System	Solar panels can be roof, rack or fence mounted. EnerWorks offers a very flexible, safe, proprietary bracket system for mounting to Unistrut or equivalent.
------------------------	---

Installer/Dealer Supplied

Heat Transfer Lines	Supply-3/8" OD copper tube Return-3/8" OD copper tube Refrigeration grade, soft copper tubing
Control Wire	18 gauge solid core, 2 wire
Insulation	Armaflex, Golf-O-Flex or equivalent insulation on the transfer lines. Vinyl wrapped or other protection such as wire mould, false downspout etc. to protect from the elements.
Solar Storage Tank	(60 Imp. Gallon/270L/80 USG preheat storage tank GSW A6921 from G.S.W. Water Heating Company. American Water Heaters E62-80H-045DV or equivalent.
Auxiliary Storage Tank	New or existing tank in good repair with at least 5 years of product life remaining. Electric, gas or oil energy source.

Distributor Information:

Solar Collectors

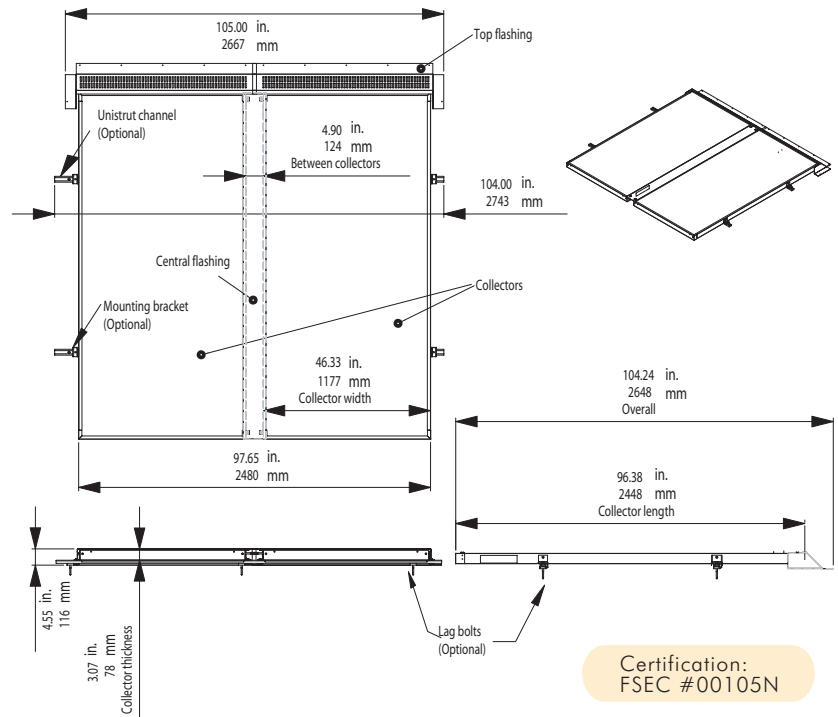

Certification:
FSEC #00105N

HX Module

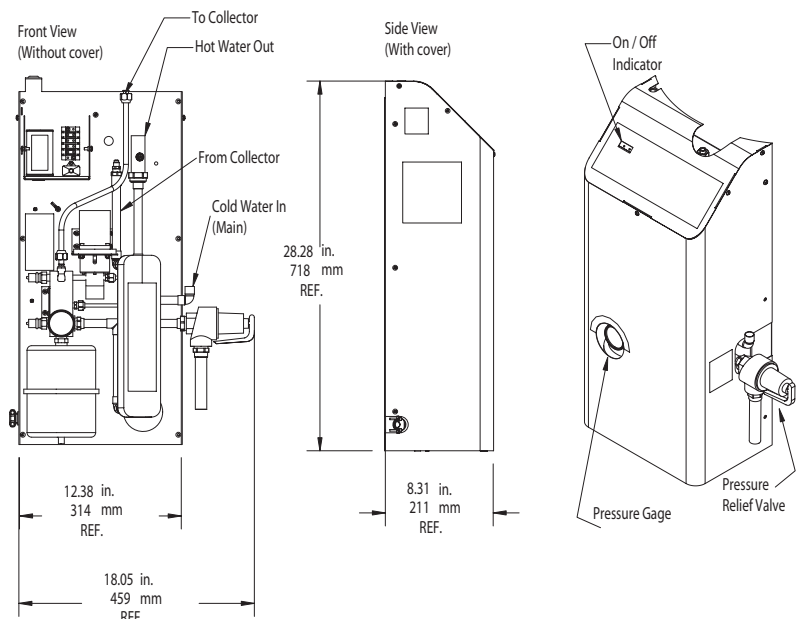

Assembled in Canada from domestic and imported components.

Printed in Canada
January 2004